

 WITTKOPP

NEW
ANCHOR
7000



Efficiency

and

Security *in*

Hybrid



Motor lock
Key lock

Application area

Safes according to
EN1143-1 grade 0 - V

Certification

- ✓ EN 1300 B
- ✓ VdS class 2
- ✓ A2P level B
- ✓ ECB ·S

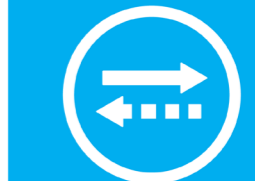

**Motor
drive**



**Boltwork
required**



ANCHOR 7000

ANCHOR 7000 is a hybrid lock system that combines advanced electronics with proven mechanics. The patented system provides both the efficiency of an electronic motor lock and the security of a mechanical key lock. Even in emergency scenarios, the conventional key lock can be quickly accessed without the need for complex cable repositioning or fitting disassembly.

Both locking mechanisms are integrated in a compact lock case with a low profile and standard mounting dimensions. This enables a quick system installation, making ANCHOR 7000 equally suitable for initial installations and retrofits.

Features

Lock	Hybrid: Electronic and mechanical locking mechanism
Bolt drive	Motor drive - 2.5 N
Levers	11
Bolt design	Spring-loaded deadbolt, 2 holes
Mounting	Standard mounting dimensions, 3 screw-on points
Mounting positions	Right / Top / Bottom
Lock case	Surface treated
Lock cover	Screwed
Tamper protection	Scanning and puncture protection
Plug connection	1 x terminal, 2 x Molex PICO-SPOX
Power supply	<ul style="list-style-type: none"> • Battery operation • External operation e.g. via burglar alarm system (requirement: GatorSIGNAL+ signal box)

Interfaces



ANCHOR 7000 is equipped with 3 different interfaces:

Port 1: Alarm interface

- Within the VdS scope: Suitable for connection of a signal box. GatorSIGNAL+ accessory required (available separately).
- Outside the VdS scope: Intended for direct connection of an alarm system

Port 2: Analog interface

- Enables connection of all analog input units of the PRIMOR series

Port 3: Serial interface (UART)

- Enables the configuration of the lock and the read out of the lock audit. The DataCONNECT interface cable is required for use (available separately). The necessary software is available in the download area.
- In addition, the serial interface enables digital communication with various input units such as touch screens or RFID readers (outside the VdS scope). The use of this digital communication not only allows remote control and monitoring of the lock, but also establishes the foundation for future expansions and developments.

Codes / Functions

User codes	9
Master codes	1
Instant opening code	✓
Operation blocking	✓
Wrong try penalty	✓
Dual mode	✓
Time delay	1-99 min
Opening window	1-19 min
Silent alarm*	✓
Remote blocking*	✓
Audit - with date and time**	<ul style="list-style-type: none"> • Operation using code and key is audited • Storage of the last 60 opening events in the VdS audit • Logging of the last 2,500 operations in the extended audit
Battery monitoring	✓

* Prerequisite in the VdS area of validity: GatorSIGNAL+ signal box

** Requirement: AnchorSELECT software and DataCONNECT interface cable

Keypads

ANCHOR 7000 can be combined with the various keypads of the PRIMOR series. This compatibility allows for tailor-made security solutions, while simultaneously increasing efficiency in the management and storage of components. Thus, ANCHOR 7000 relies not only on innovative technologies but also on a thoughtful and flexible system architecture. This targeted approach meets the requirements of modern security concepts and consistently ensures the highest standards.



PRIMOR SI



PRIMOR RO



PRIMOR FSM



PRIMOR FL



PRIMOR LC

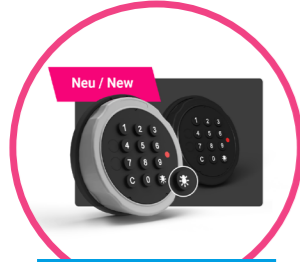

PRIMOR SI

- Die-cast zinc housing
- Backlit keys
- Keypad mat with tactile feedback
- Numeric keys
- 1 LED for status messages
- Integrated battery compartment, accessible from the outside
- 1 x 9 volt block battery*

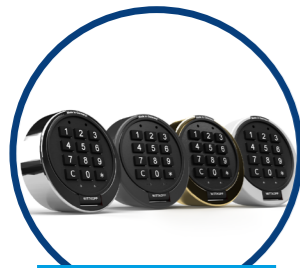

PRIMOR FSM

- Die-cast zinc housing
- Keypad mat with tactile feedback
- Numeric keys
- 2 LEDs for status messages
- Integrated battery compartment, accessible from the outside, magnetic closure
- 1 x 9 volt block battery*



PRIMOR FL

- Die-cast zinc housing
- Keypad mat with tactile feedback
- Numeric keys
- 2 LEDs for status messages
- Separate battery compartment
- Emergency power supply via contact points from the outside
- 1 x 9 volt block battery*



PRIMOR RO

- Plastic housing
- Membrane keypad with closed operating surface
- Numeric keys
- 1 LED for status messages
- Integrated battery compartment, accessible from the outside
- 1 x 9 volt block battery*



PRIMOR LC

- Plastic material
- Membrane keypad with closed operating surface
- Numeric keys
- 1 LED for status messages
- Adhesive surfaces for fastening
- Separate battery compartment
- Emergency power supply via contact points from the outside
- 1 x 9 volt block battery*

PRIMOR series

Article overview

Article number	Article description
A-7000-01-0-Z170-1	ANCHOR 7000 lock incl. 1 key die-cast zinc, 170 mm / system cable
P-FS-M-00-00-0-00	Keypad PRIMOR FSM - gloss chrome-plated
P-FS-M-00-00-1-00	Keypad PRIMOR FSM - satin chrome-plated
P-FS-M-00-00-2-00	Keypad PRIMOR FSM - gold-plated
P-FS-M-00-00-7-00	Keypad PRIMOR FSM - black powder-coated, fine-textured
P-FL-00-03-1-00	Keypad PRIMOR FL - satin chrome-plated (without battery compartment)
P-FL-00-03-2-00	Keypad PRIMOR FL - gold-plated (without battery compartment)
P-FL-00-03-7-00	Keypad PRIMOR FL - black powder-coated, fine-textured (without battery compartment)
P-LC-00-00-7-00	Keypad PRIMOR LC - black (without battery compartment)
BAT-MM-0460	Battery drawer for PRIMOR FL / LC, 460 mm
BAT-MM-1500	Battery drawer for PRIMOR FL / LC, 1,500 mm
P-RO-00-01-0-00	Keypad PRIMOR RO - ring black
P-RO-00-01-1-00	Keypad PRIMOR RO - ring gloss chrome-plated
P-SI-00-00-1-00	Keypad PRIMOR SI - satin chrome-plated
P-SI-00-00-7-00	Keypad PRIMOR SI - black
CABLE-SET-DC	DataCONNECT interface cable set incl. adapter / system cable
G-SIGNAL-PLUS	GatorSIGNAL+ signal box incl. system cable
G-POWER-12	Power supply unit 12VDC/2A for signal box GatorSIGNAL+
	AnchorSELECT software available in Downloads on WITTKOPP website www.carl-wittkopp.com

Further products

ANCHOR locks impress at first glance with a reduced overall height, recessed screw heads, and a narrow bolt. These distinctive features make them ideal for installation in small safes.

However, it's not just about the exterior: The locks come equipped with a digital interface for applications such as remote maintenance or apps.

ANCHOR locks can be combined with various keypads and signal boxes from the PRIMOR series. This high compatibility of components underscores the great flexibility of ANCHOR while also providing advantages in storage management

ANCHOR Series



ANCHOR 2600



ANCHOR 4300

Technical drawing

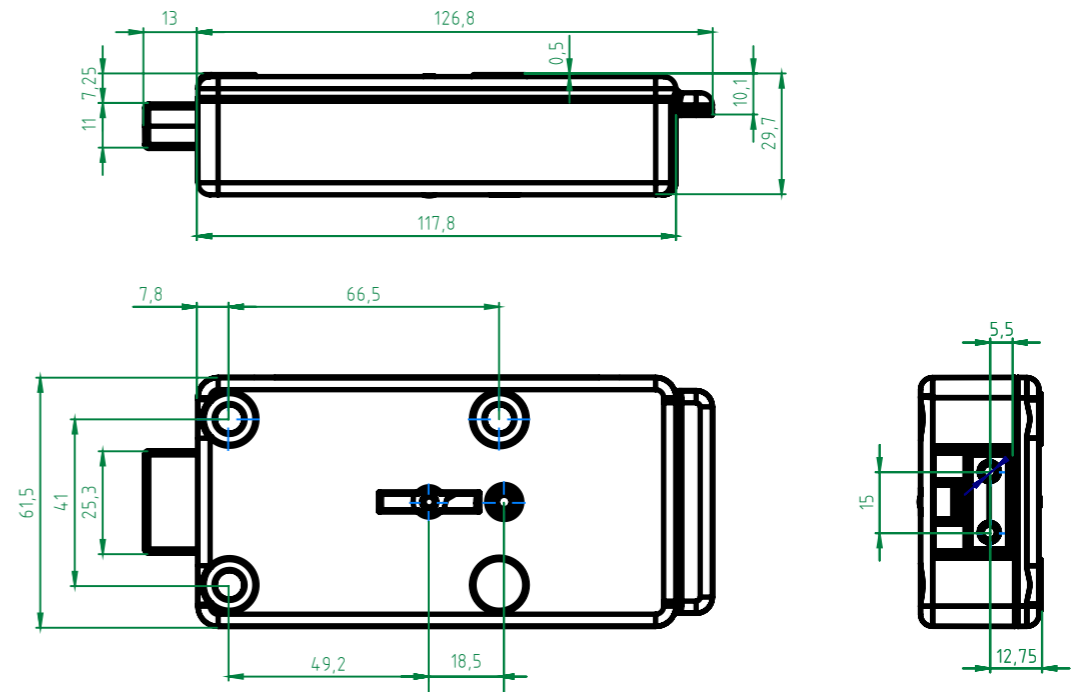

Length	127 mm
Width	61.5 mm
Height	30 mm
Bolt exclusion (min)	13 mm

Weight

Lock weight	670 g
-------------	-------

Mounting screws

Type	M6 x 28 DIN 7985
Tightening torques	Max. 3.5 - 5 Nm



Carl WITTKOPP GmbH

Am Lindenkamp 57 • D-42549 Velbert

Telephone: +49 (0)2051 9566 0

Email: info@carl-wittkopp.com

© Carl Wittkopp GmbH - Subject to errors and omissions
Revision 22.01.2024

